

reserved pins are preferred to be used for future internal hardware uses rather than to be broken out

DC Input Jack

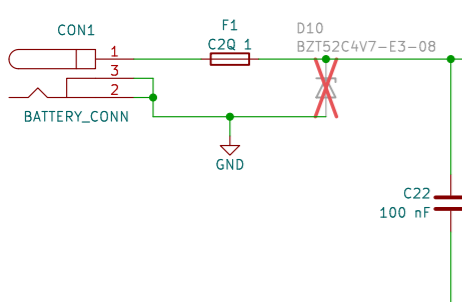

Serial USB Conn

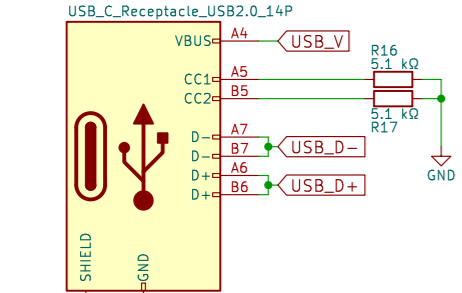

MCU Reset

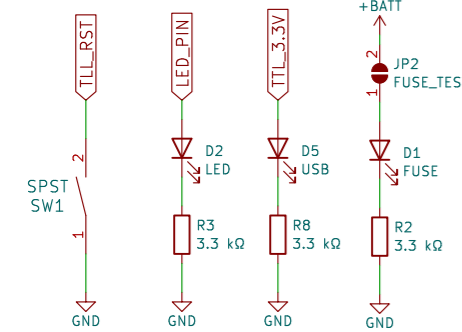

3.3V Voltage Regulation

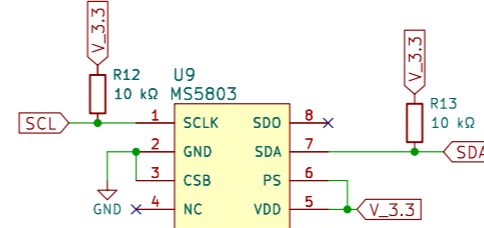
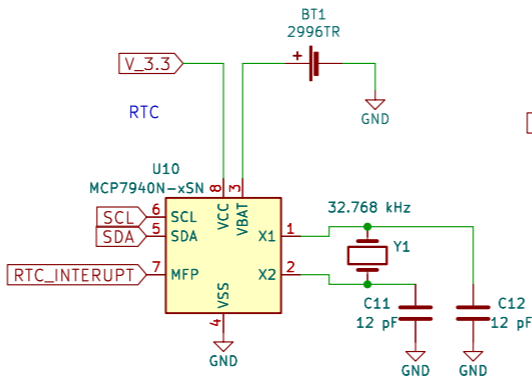
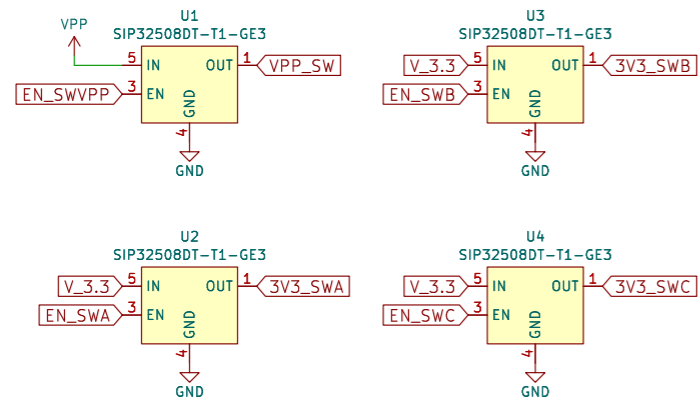
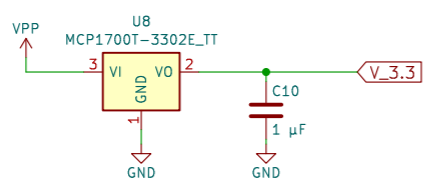

Mounting Holes

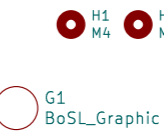

Add breakout board

